

Performance of the primary-standard resistance thermometry bridge model CTR9000 (F900)

WIKA data sheet IN 00.31

The model CTR9000 primary-standard resistance thermometry bridge is designed specifically for resistance thermometry to provide the best possible accuracy. Work on validating the performance lasted 1 ½ years. During this time a large number of tests were being performed. This report provides details of some of the key tests used to determine the more critical aspects of the CTR9000 (F900) performance.

The work was carried out in the research and development department, which is not air-conditioned, ambient temperatures therefore varied between about 16 °C and 30 °C. This environment is not ideal for precision electrical measurement. It is therefore realistic to expect that the CTR9000 (F900) should equal or exceed the performance indicated by these tests when used in most temperature laboratories, provided good measurement.



Model CTR9000 primary-standard resistance thermometry bridge, version 20 ppb accuracy

Accuracy

A key performance parameter for the model CTR9000 (F900) primary-standard resistance thermometry bridge is its accuracy, since this ultimately limits the measurement uncertainty that can be achieved using the bridge. The high accuracy of ±20 ppb claimed in the specification is difficult to validate. This is due to the uncertainty of the tests used and the difficulty, in finding suitable products for use in such tests. Following approaches were taken to validate the accuracy:

Internal consistency check

The model CTR9000 (F900) primary-standard resistance thermometry bridge uses a ratio transformer to make the measurement (figure 1):

Fig. 1: Measurement concept

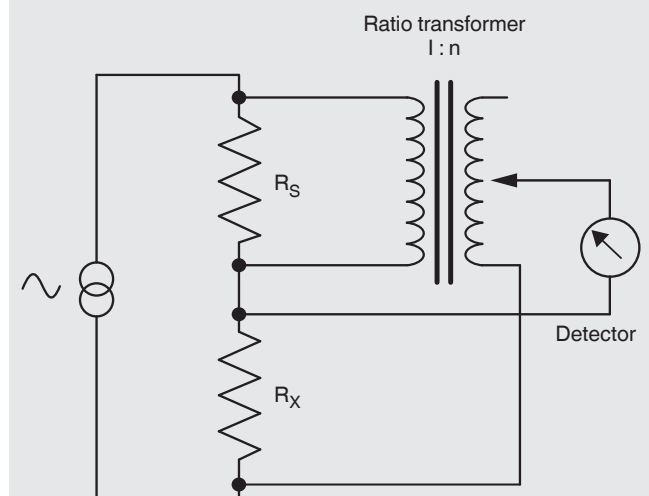

The two resistances R_S and R_X carry the same current. The ratio transformer is used to balance the voltage developed across an unknown resistance (R_X) against that across a known standard resistance (R_S). Since the ratio of the voltage across the primary and secondary of an ideal transformer is equal to the turns-ratio (n), the ratio of the resistances R_X and R_S then equals the turns-ratio:

$$R_X = n \cdot R_S \text{ (at balance)}$$

The ratio transformer is actually a series of cascaded transformers. Each transformer has tapings in decimal intervals (10:1, 10:2, 10:3 ... 10:9) and provides one decade of resolution for the bridge. Since the tapped secondary comprises a number of individual windings, it is possible to connect any two of these windings "back-to-back" and use a sensitive detector directly to measure the difference between them. From this we can calculate the linearity errors that would occur when the winding segments are built up into the complete secondary winding.

However, this approach does not subject the windings to the common voltages they will experience in practice. This is important since the complex interwinding capacitance relationships will inject current that depends on these common mode voltages. The approach used was therefore to connect all the segments of the secondary in their intended arrangement and to compare these with a reference winding. The ratio transformer has two "extra" windings that normally drive subsequent decades and one of these was used as the reference in the measurement.

The most significant 'decade' actually provides a ratio up to 1.2 to give the required range for thermometry. This decade effectively determines the measurement linearity, since it is here where the signals are greatest and therefore where any ratio errors have the most impact on the measurement. The winding inter-comparison was made on this decade in order to confirm the resistance thermometry bridge measurement linearity. The results (with measurement uncertainties) are shown in figure 2.

Fig. 2: Non-linearity caused by ratio transformer errors

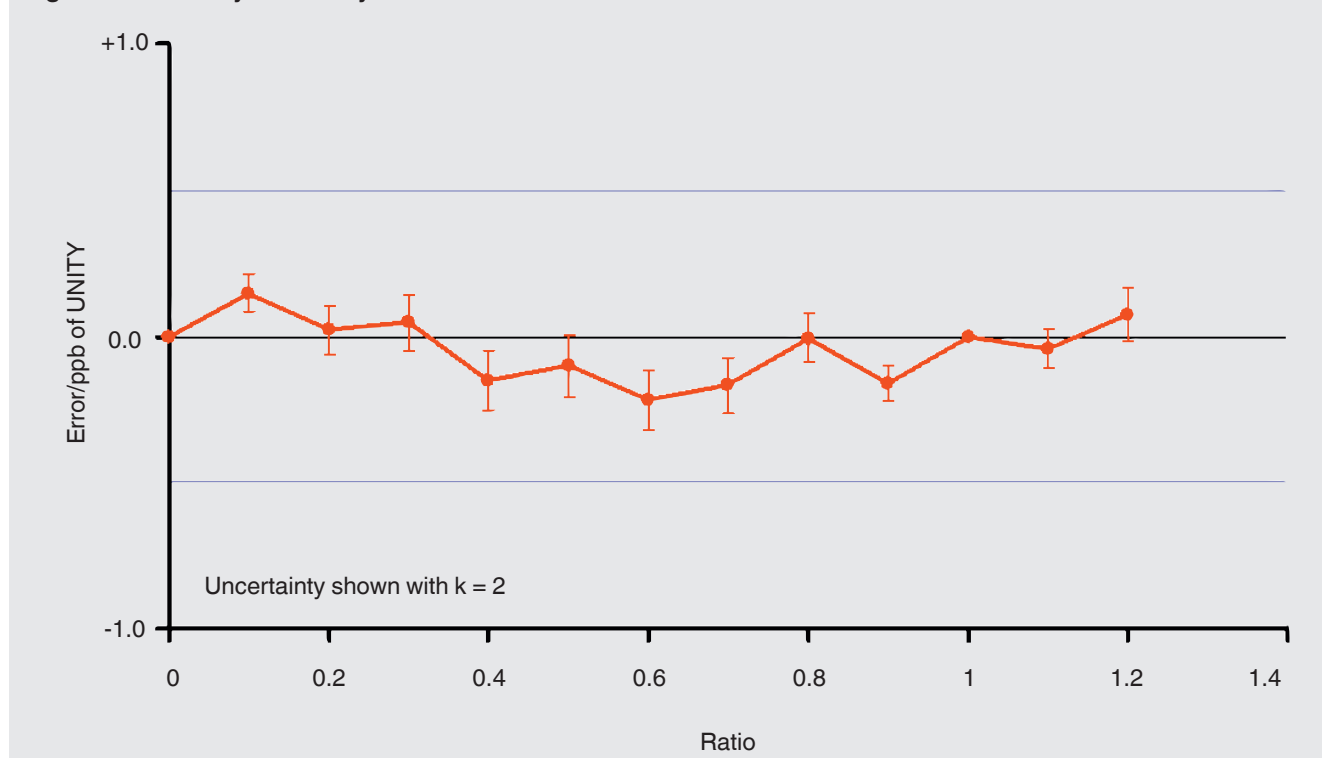

This test confirms that the non-linearity caused by ratio errors in the transformer is less than 1 ppb and is therefore insignificant compared with the specified performance of 20 ppb.

This test measures linearity only; it does not check whether the full winding accurately provides a ratio of unity. Any errors in either the zero or unity ratio measurements further contribute to the total measurement accuracy achieved by the resistance thermometry bridge.

However, it is straightforward to check "unity" performance by connecting the potential terminal for R_X to R_S .

It is also easy to check "zero" performance by connecting a four-terminal short-circuit in place of R_X . These test functions are built into the bridge and made available via front panel keys. They provide a simple and useful instrument performance check.

Complement check

Although the model CTR9000 (F900) primary-standard resistance thermometry bridge is equipped with a UNITY self-test function, it is desirable to check the accuracy of the ratio measurements when using actual resistors.

This can be achieved by connecting two resistors of similar value to the bridge and measuring the ratio, then swapping over the resistors and re-measuring the ratio. The ratios should be the reciprocal of each other so that the product of the two ratios should be unity. The measurement error is therefore half the difference between the product of the two ratios and unity.

Two Wilkins resistors were used in the tests. Although the temperature coefficient and power coefficient of these resistors are low, they are significant at the level of measurement (ppb) we are working at. The interruption of the power to the resistors whilst they are being swapped over manually causes the temperature and therefore the resistance of the resistors to change significantly followed by a relatively long recovery.

This was overcome in the tests by using reed relays to swap over connections to the resistors within a few milli-seconds, a time frame that is short enough to have no negligible impact on the resistance.

The temperature coefficient of the resistors (2 ppm/°C) mean that a 1 mK change in temperature yields a 2 ppb error. The resistors used in the test were therefore chosen to have matched temperature coefficients, they were used in a stable temperature environment and the measurements were taken quickly in order to minimise the effect of temperature coefficient on the measurement.

The result of complement checks in a number of resistance thermometry bridges is shown in table 1. The complement checks confirm that the ratio accuracy of the bridge at unity is within specification.

Table 1: Complement errors measured

CTR9000 (F900) S/N	R1/R2	R2/R1	R1/R2 x R2/R1	Error/ppb
7869005009	1.000037014	0.999963000	1.000000013	-6.5
7869001005	1.000035132	0.999964862	0.999999992	4
78669003007	1.000032194	0.999967804	0.999999997	1.5

Comparison with a traceable IVD

Although the design calculations and measurements on the ratio transformer indicate that the model CTR9000 (F900) primary-standard resistance thermometry bridge achieves the stated accuracy, it wanted to find some way of providing a performance check for the whole instrument that was traceable to national standards.

For this, a ratio test unit (RTU) was used, which is an inductive voltage divider (IVD) of our own design that is used as a company reference standard.

The RTU provides ratios in integer multiples of elevenths; this particular ratio set is useful as it exercises all the digits of every decade when used over the range zero to unity and thereby provides a thorough check of the ratio tappings. The RTU was sent to PTB, the national standards laboratory of Germany for calibration.

The uncertainties ($k = 2$) for both measurements are shown by the “error bars”. Interestingly, the resistance thermometry bridge “error” is a mirror image of the calibration ‘error’ determined by PTB.

This suggests that the calibration ‘errors’ determined in this test are the result of “errors” in the values assigned by PTB in their calibration and are not real. This does not mean that the PTB values are wrong, since the nominal or design values for the RTU are comfortable within the uncertainties declared by PTB.

With the uncertainties available on the PTB calibration of the RTU, it is not possible to use this test alone to confirm the accuracy. However, the striking mirror image relationship between the two results together with the design calculations for the RTU support the view that it is legitimate to use the nominal RTU ratios in the test.

If WIKA use the nominal design values for the RTU in the calibration test, we find that the errors are very small. The maximum error is only 14 ppb and the standard deviation is 5 ppb.

The internal consistency checks confirm that the linearity of key components within the resistance thermometry bridge

measurement system easily achieve the stated 20 ppb accuracy. Additionally, the comparison of the resistance thermometry bridge against the RTU indicates that the linearity of the complete) instrument is within its specification.

Noise

Although not part of the formal specification of the instrument, the noise performance of the model CTR9000 (F900) primary-standard resistance thermometry bridge is vital in determining the measurement uncertainty that can be achieved with this equipment.

The resistance thermometry bridge measures resistance ratio by balancing the voltage across the known and unknown resistances using a ratio transformer. The complex electronics surrounding the transformer serve to 'bootstrap' the transformer so that the magnetising currents in the transformer do not load the resistances significantly as this would lead to measurement errors. These circuits do not directly form part of the measurement circuit, so their contribution to noise is limited to the noise on the very small bias currents drawn by the amplifiers that are connected to the potential leads of the resistance R_S .

The null balance detector used also contributes to the measurement noise. The bridge impedance is matched to the noise impedance of the detector using a transformer in order to optimise measurement noise. For an ideal transformer, any resistance 'seen' through a transformer has its impedance transformed by 2:1.

The detector system noise (referred to the detector amplifier input) can be viewed as an equivalent voltage noise (V_N) and current noise (I_N) as shown in figure 3.

The easiest way to determine the contribution of detector noise to the total measurement noise is to refer the detector noise components to position XX.

Fig. 3: Noise matching system used

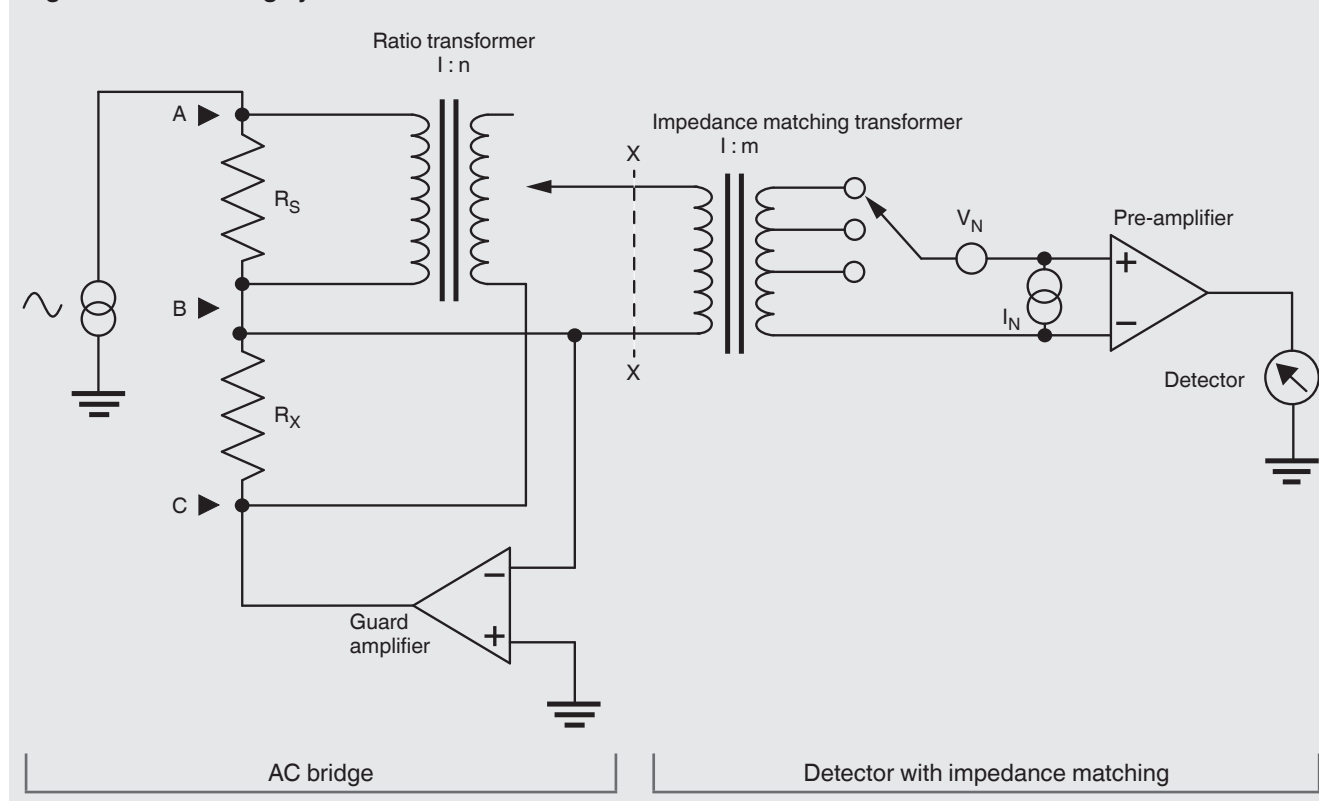

At this point the impedance of the bridge is:

$$R_B = R_X + n \cdot 2 \cdot R_S$$

Note:

When measuring low resistances (high-temperature SPRTs or cryogenic applications), the lead resistances are significant and need to be included in the calculation of bridge impedance.

For the purpose of this analysis they are ignored, so the noise V_N at X-X is given by:

$$V_N \cdot 2 = [m \cdot I_N \cdot R_B] \cdot 2 + [V_N]^2$$

The optimum (lowest V_N^2) value for m (transformer setting) is determined by differentiating this expression w.r.t. m and setting this to zero to yield:

Minimum noise when:

$$V_N = m \cdot 2 \cdot R \cdot B$$

Considering that an ideal transformer transforms any impedance by n^2 , this is equivalent to stating that optimum noise performance is achieved when the transformer matches the detector **noise** impedance to the measurement circuit impedance. This noise matching facility enables the resistance thermometry bridge to approach the fundamental Johnson Noise limit over the normal resistance measurement range used in thermometry.

For example:

The fundamental Johnson Noise on a 25.5 Ω standard platinum resistance thermometer (SPRT) at 0 °C measured with a 0.5 Hz bandwidth is 893 pV and the measurement noise achievable with a properly configured CTR9000 (F900) is equivalent to only 958 pV (only 7 % above the fundamental limit).

An Excel spreadsheet has been produced that calculates the theoretical noise figure for the resistance thermometry bridge for any operating conditions (this can be supplied to model CTR9000 (F900) primary-standard resistance thermometry bridge customers to assist in predicting uncertainty budgets).

These predict that for a 10 Ω resistance measured at 25 °C the resistance thermometry bridge (set to 10 Ω impedance) would exhibit an RMS ratio noise of 62 ppb at 0.7071 mA and 9 ppb at 5 mA.

The corresponding measurements were made using Wilkins standard resistors in a temperature stabilized oil bath, with the results shown in table 2.

Table 2: Calculated and measured noise figures

Test current	Calculated RMS noise	Measured RMS noise
0.7071 mA	62 ppb	57 ppb
5 mA	9 ppb	5 ppb

The measurements confirm that the noise performance of the is as predicted by the design calculations and closely approaches the fundamental Johnson Noise limit.

Bridge current accuracy

The accuracy of the bridge current is important because of the self-heating effect in a standard platinum resistance thermometer (SPRT). This causes the resistance of the SPRT at a given temperature to be dependent on the measurement current to an extent that is significant at the target uncertainty level of 20 ppb.

The accuracy of the bridge current is therefore important if the SPRT is to be used as a transfer standard thermometer at a stated current or if the bridge current is to be varied to allow extrapolation back to the zero-power resistance. The bridge current was measured using a Keithley model 2000 multimeter to measure the voltage developed across a calibrated Wilkins resistor.

The errors between the measured and expected current for all bridge settings are shown in table 3.

This test confirms that the current accuracy is comfortably within the specified $\Omega \pm 0.1 \%$.

Table 3: Bridge current error

Bridge setting in mA	Error in %
50√2	0.01
50	-0.01
20√2	0.01
20	-0.01
10√2	0.02
10	0.05
5√2	-0.02
5	-0.04
2√2	-0.03
2	-0.04
√2	-0.01
1	0.02
0.5√2	0.01
0.5	-0.01
0.2√2	0.00
0.2	-0.01
0.1√2	0.02
0.1	0.05

Conclusion

As stated at the beginning, the above test results are a limited selection of the extensive tests carried out on the model CTR9000 (F900) primary-standard resistance thermometry bridge over the last 18 months. However, these tests are the ones that address the most important performance criteria for this instrument (accuracy, noise and bridge current accuracy). These tests confirm the performance of this resistance thermometry bridge to be well within its performance specification.

The resistance thermometry bridge is designed to be as immune to environmental effects (particularly electrical noise and temperature) as possible. It should therefore be possible for users to achieve the specified performance. It is however important for users to set up the primary-standard resistance thermometry bridge correctly in order to achieve this performance. In particular, users must set the bridge gain correctly (as documented in the operating instructions).

