

### Resistance thermometer Compact design Model TR30

WIKA data sheet TE 60.30



for further approvals  
see page 8

#### Applications

- Machine building, plant and vessel construction
- Propulsion technology, hydraulics
- General applications

#### Special features

- Measuring ranges from -50 ... +250 °C (-58 ... +482 °F), accuracy class per DIN EN 60751
- TR30-W: integrated transmitter, programmable and able to be calibrated via software
- Electrical connection via DIN angular connector or circular connector
- Process connection and sensor tube from stainless steel



Fig. left: with circular connector M12 x 1  
Fig. right: with DIN angular connector

#### Description

Resistance thermometers of this series are used as universal thermometers for the measurement of liquid and gaseous media.

They can be used for pressures up to 40 bar (special designs to 400 bar dependent on insertion length and diameter). All electrical components are protected against splashed water and are designed to withstand vibration.

The TR30 resistance thermometer consists of a sensor tube, which can be fixed into the process using a permanently-welded threaded connection or a compression fitting. A version with no process connection is also available. The electrical connection is made via a DIN angular connector or an M12 x 1 circular connector.

#### Output signal Pt100

The model TR30-P resistance thermometer is available with a direct Pt100 signal. An intrinsically safe variant can be supplied as an option.

#### Output signal 4 ... 20 mA

In the model TR30-W resistance thermometer, a software-programmable transmitter with a 4 ... 20 mA output signal is built in. Thus the measured temperature values can be transmitted safely and simply.

**Specifications****Thermometer with direct sensor output with Pt100 output signal, model TR30-P**

<b>Temperature range</b>	
■ Class A	Without neck tube -30 ... +150 °C (-22 ... +302 °F) With neck tube -30 ... +250 °C (-22 ... +482 °F)
■ Class B	Without neck tube -50 ... +150 °C (-58 ... +302 °F) With neck tube -50 ... +250 °C (-58 ... +482 °F)
<b>Measuring element</b> (measuring current: 0.1 ... 1.0 mA)	Pt100 measuring resistor
<b>Connection method</b>	<ul style="list-style-type: none"> <li>■ 2-wire</li> <li>■ 3-wire</li> <li>■ 4-wire</li> </ul>
<b>Measuring element tolerance value per IEC 60751</b>	<ul style="list-style-type: none"> <li>■ Class B</li> <li>■ Class A</li> </ul>
<b>Electrical connection</b>	<ul style="list-style-type: none"> <li>■ M12 x 1 circular connector (4-pin)</li> <li>■ DIN angular connector form A for cables with Ø 6 ... 8 mm, cross section max. 1.5 mm<sup>2</sup></li> </ul>

For detailed specifications for Pt sensors, see Technical information IN 00.17 at [www.wika.com](http://www.wika.com).

**Thermometer with transmitter and 4 ... 20 mA output signal, model TR30-W**

<b>Temperature range</b> <sup>1)</sup>	
■ Class A	Without neck tube -30 ... +150 °C (-22 ... +302 °F) With neck tube -30 ... +250 °C (-22 ... +482 °F)
■ Class B	Without neck tube -50 ... +150 °C (-58 ... +302 °F) With neck tube -50 ... +250 °C (-58 ... +482 °F)
<b>Measuring element</b> (measuring current: 0.5 mA)	Pt100 measuring resistor
<b>Tolerance value of the measuring element</b> <sup>1)</sup> per IEC 60751	<ul style="list-style-type: none"> <li>■ Class B</li> <li>■ Class A</li> </ul>
<b>Measuring span</b>	Minimum 20 K, maximum 300 K
<b>Basic configuration</b>	Measuring range 0 ... 150 °C, other measuring ranges are adjustable
<b>Analogue output</b>	4 ... 20 mA, 2-wire
<b>Measuring deviation per IEC 60770, 23 °C ±5 K</b>	1 % (Transmitter) <sup>2)</sup>
<b>Linearisation</b>	Linear to temperature per IEC 60751
<b>Linearisation error</b>	±0.1 % <sup>3)</sup>
<b>Switch-on delay, electrical</b>	< 10 ms
<b>Current signal for fault signal</b>	Configurable in accordance with NAMUR NE43 downscale ≤ 3.6 mA                      upscale ≥ 21.0 mA
<b>Sensor short-circuit</b>	Not configurable, generally NAMUR downscale ≤ 3.6 mA
<b>Load R<sub>A</sub></b>	$R_A \leq (U_B - 9 V) / 0.023 A$ with R <sub>A</sub> in Ω and U <sub>B</sub> in V
<b>Effect of load</b>	±0.05 % / 100 Ω
<b>Power supply U<sub>B</sub></b>	DC 10 ... 35 V
<b>Max. permissible residual ripple</b>	10 % at 24 V / maximum 300 Ω load
<b>Power supply input</b>	Protected against reverse polarity
<b>Power supply effect</b>	±0.025 % / V
<b>Electromagnetic compatibility (EMC)</b>	EN 61326 emission (group 1, class B) and interference immunity (industrial application) <sup>4)</sup> , and also per NAMUR NE21
<b>Temperature units</b>	Configurable °C, °F, K
<b>Info data</b>	TAG No., descriptor and message can be stored in transmitter
<b>Configuration and calibration data</b>	Permanently stored in EEPROM
<b>Electrical connection</b>	<ul style="list-style-type: none"> <li>■ M12 x 1, 4-pin circular connector</li> <li>■ DIN angular connector form A for cables with Ø 6 ... 8 mm, cross section max. 1.5 mm<sup>2</sup></li> </ul>

Readings in % refer to the measuring span

For a correct determination of the overall measuring error, both sensor and transmitter measuring deviations have to be considered.

1) The temperature transmitter should therefore be protected from temperatures over 85 °C (185 °F)

2) For measuring spans smaller than 50 K additional 0.1 K

3) ±0.2 % for measuring ranges with a lower limit less than 0 °C (32 °F)

4) Use resistance thermometers with shielded cable, and ground the shield on at least one end of the lead, if the lines are longer than 30 m or leave the building.

Ambient conditions	
<b>Ambient and storage temperature</b>	-40 ... +85 °C (-40 ... +185 °F) Model TR30-P with DIN angular connector: -40 ... +125 °C (-40 ... +257 °F)
<b>Ingress protection</b>	IP67 per IEC/EN 60529 for circular connector M12 x 1 IP65 per IEC/EN 60529 for DIN angular connector form A The stated ingress protection only applies when plugged in using mating connectors that have the appropriate ingress protection.
<b>Accuracy <sup>5)</sup></b>	-1 Kelvin
<b>Response time</b>	t <sub>50</sub> < 5 s   t <sub>90</sub> < 10 s (for sensor diameter 6 mm)
<b>Materials (case and process connection)</b>	Stainless steel
<b>Vibration resistance</b>	<ul style="list-style-type: none"> <li>■ 3 g (IEC 60751, standard)</li> <li>■ 20 g (IEC 60751, special designs, up to a max. insertion length of 160 mm, no compression fittings)</li> </ul>

Sensor tube	
<b>Materials</b>	Stainless steel 1.4571 (316Ti)
<b>Process connection (welded / compression fitting) Thread per DIN 3852, form A</b>	<ul style="list-style-type: none"> <li>■ G ¼ B (not for sensor diameter 8 mm)</li> <li>■ G ⅜ B</li> <li>■ G ½ B</li> <li>■ ¼ NPT (not for sensor diameter 8 mm)</li> <li>■ ½ NPT</li> <li>■ without</li> </ul>
<b>Sensor insertion lengths</b>	25, 50, 75, 100, 120, 150, 200, 300, 400 or 500 mm (other insertion lengths possible; ask for delivery times)
<b>Sensor diameter</b>	<ul style="list-style-type: none"> <li>■ 3 mm (only for insertion length 25 mm) <sup>6)</sup></li> <li>■ 6 mm (insertion lengths 50 ... 500 mm)</li> <li>■ 6 mm, tapered to 3 mm (insertion lengths 50 ... 500 mm)</li> <li>■ 8 mm (insertion lengths 50 ... 500 mm)</li> </ul>

5) Measured at 100 °C (212 °F)

6) The use of a compression fitting is excluded.

**Note:**

The resistance thermometers of the series TR30 are designed for direct installation into the process. Using it in an additional thermowell makes no sense.

**Dimensions in mm**

**Process connection with parallel threads (or without process connection)**

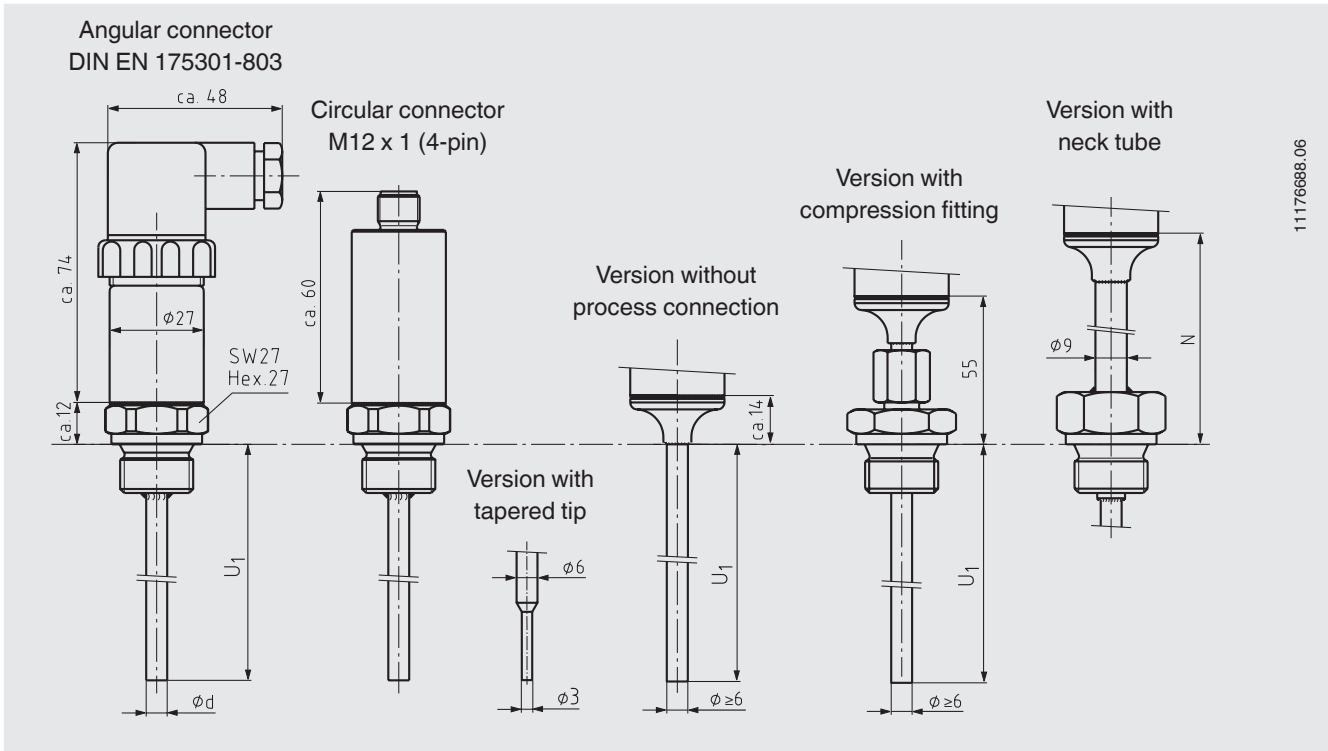

11176688.06

**Process connection with tapered threads**

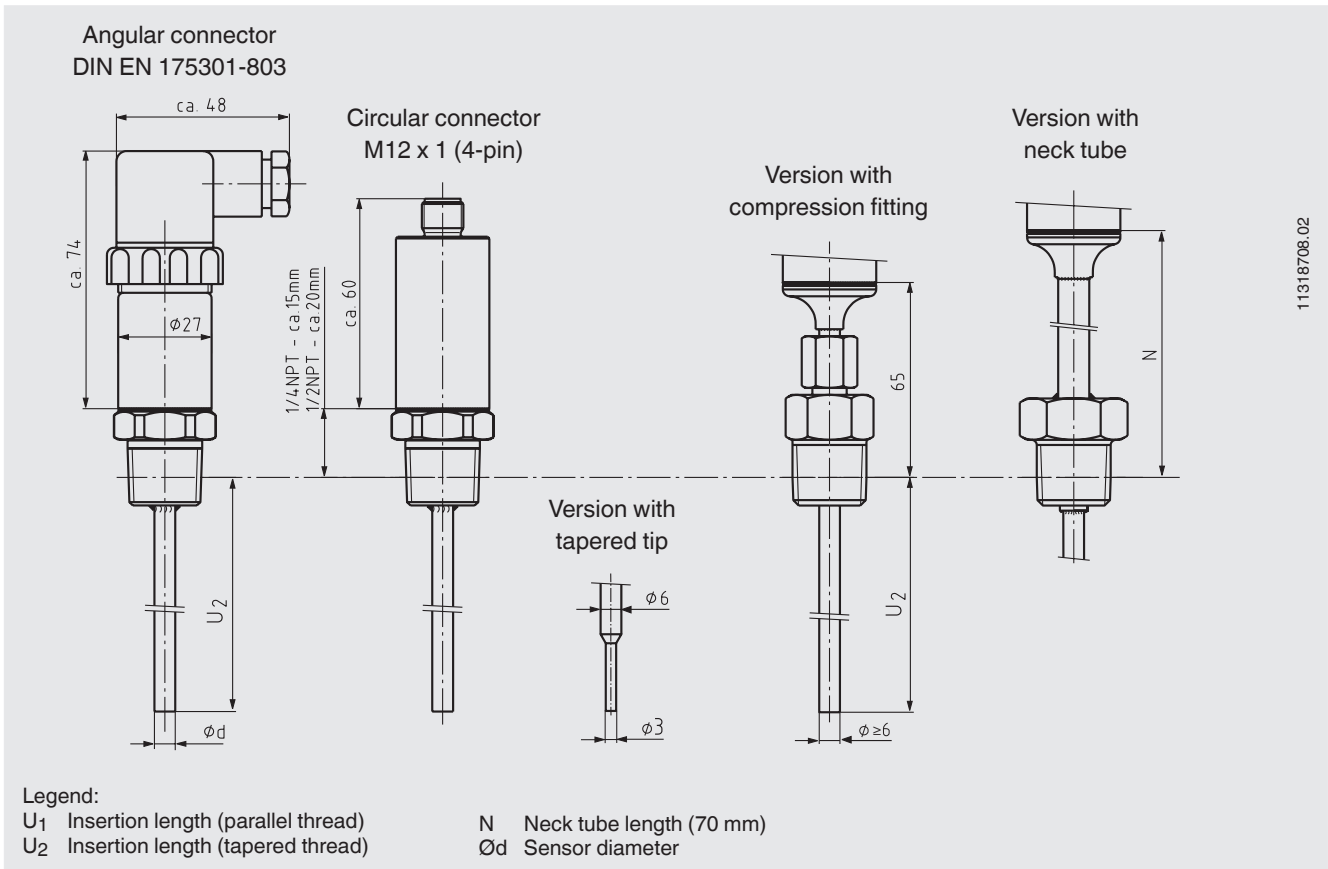

11318708.02

**Legend:**

$U_1$  Insertion length (parallel thread)  
 $U_2$  Insertion length (tapered thread)

N Neck tube length (70 mm)  
 $\phi d$  Sensor diameter

## Configuration software WIKAsoft-TT

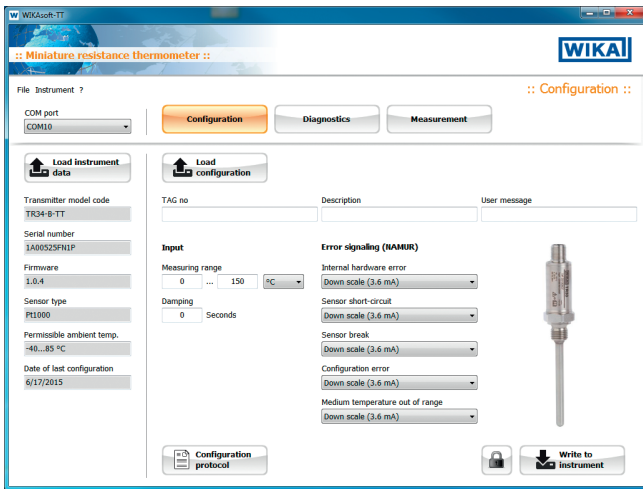

Configuration software (multilingual) as a download from [www.wika.com](http://www.wika.com)

## Accessories

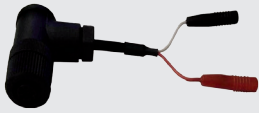
Model	Special features	Order no.
<b>Programming unit</b> <b>Model PU-548</b> 	<ul style="list-style-type: none"> <li>■ Easy to use</li> <li>■ LED status display</li> <li>■ Compact design</li> <li>■ No further voltage supply needed, neither for the programming unit nor for the transmitter</li> </ul> <p>(replaces programming unit model PU-448)</p>	14231581
<b>Adapter cable M12 to PU-548</b> 	Adapter cable for the connection of model TR30-W resistance thermometer to the model PU-548 programming unit	14003193
<b>Adapter cable</b> <b>DIN angular connector to PU-548</b>	Adapter cable of the DIN angular connector for the connection of a model TR30-W resistance thermometer with a DIN EN 175301-803 form A angular connector to the model PU-548 programming unit	14005324

### Connecting PU-548 programming unit

Connection PU-548 ↔ adapter cable with M12 connector

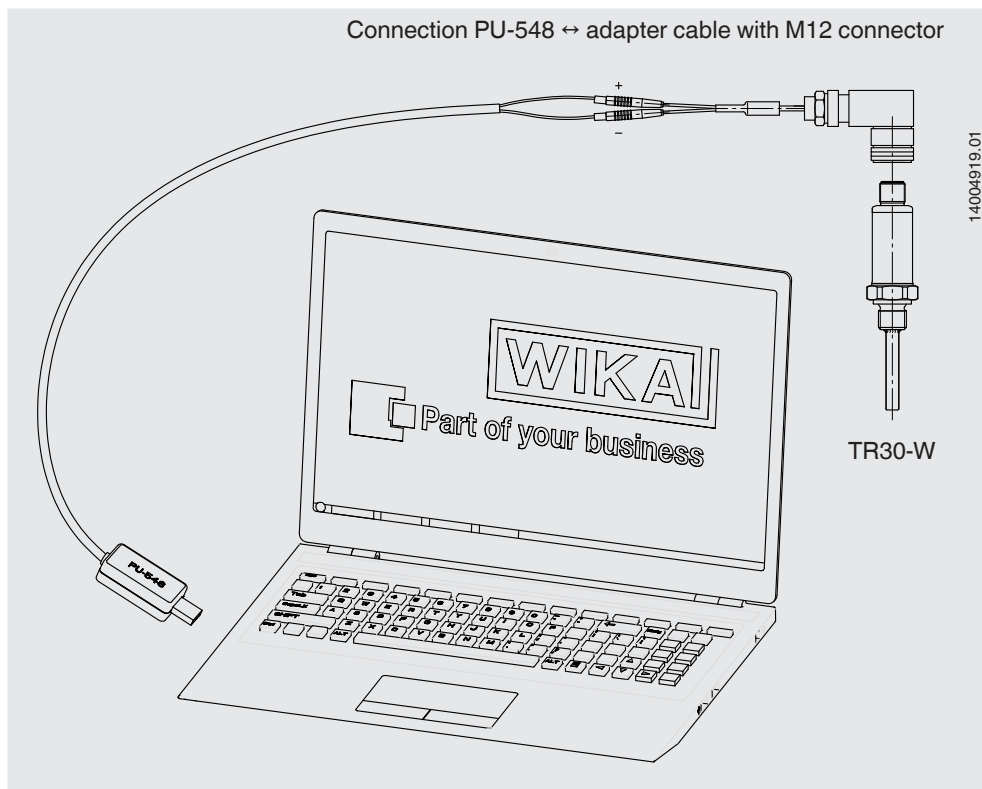

Connection PU-548 ↔ adapter cable with DIN angular connector, form A

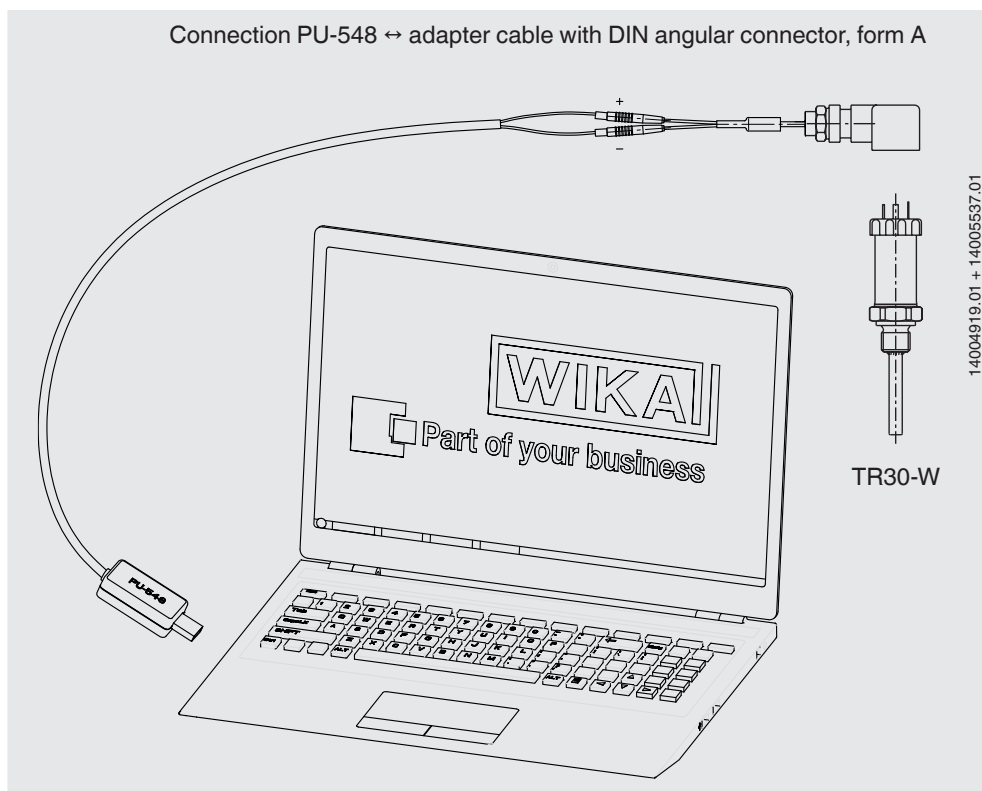

(predecessor, programming unit model PU-448, also compatible)

**Electrical connection**

■ Output signal Pt100, model TR30-P

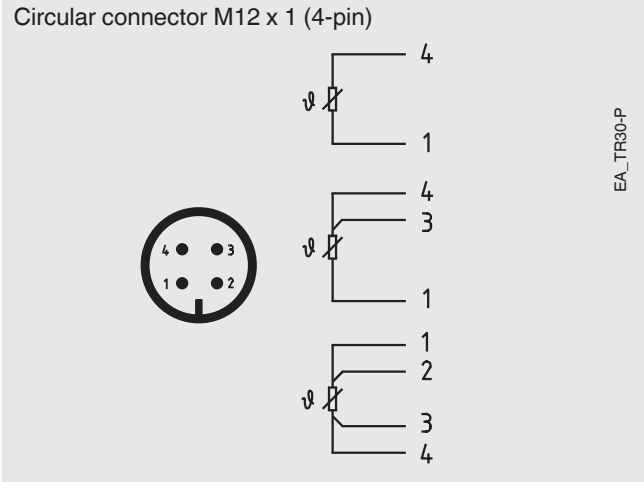
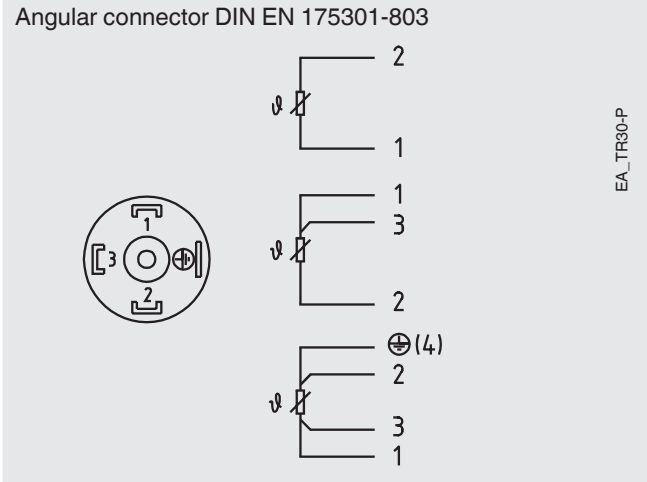

■ Output signal 4 ... 20 mA, model TR30-W

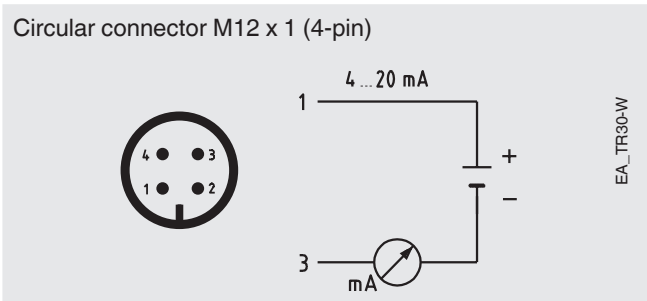
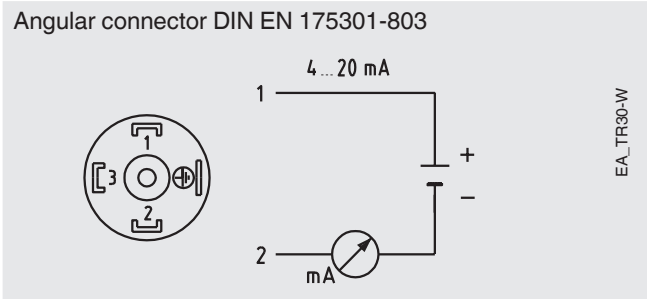





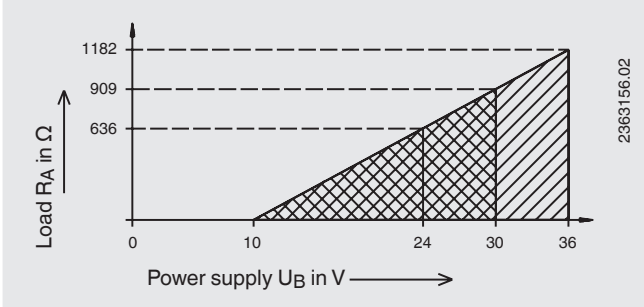

**Load diagram for model TR30-W**

The permissible load depends on the loop supply voltage.



## Approvals

Logo	Description	Country
	<b>EU declaration of conformity</b> <ul style="list-style-type: none"> <li>■ EMC directive <sup>1)</sup></li> <li>EN 61326 emission (group 1, class B) and interference immunity (industrial application)</li> <li>■ RoHS directive</li> </ul>	European Union
	<b>EAC (option)</b> EMC directive <sup>1)</sup>	Eurasian Economic Community
	<b>GOST (option)</b> Metrology, measurement technology	Russia
	<b>KazInMetr (option)</b> Metrology, measurement technology	Kazakhstan
-	<b>MTSCHS (option)</b> Permission for commissioning	Kazakhstan
	<b>UkrSEPRO (option)</b> Metrology, measurement technology	Ukraine
	<b>Uzstandard (option)</b> Metrology, measurement technology	Uzbekistan

1) Only for built-in transmitter

## Certificates (option)

- 2.2 test report
- 3.1 inspection certificate
- DKD/DAkkS calibration certificate

Approvals and certificates, see website

## Ordering information

Model / Output signal / Mechanical tests / Electrical connection / Neck tube / Process connection / Measuring element / Connection method / Temperature range / Transmitter initial value / Transmitter end value / Sensor diameter / Sensor insertion length / Certificates / Options

© 01/2008 WIKA Alexander Wiegand SE & Co. KG, all rights reserved.  
The specifications given in this document represent the state of engineering at the time of publishing.  
We reserve the right to make modifications to the specifications and materials.

